

LP Mobile Radial Stockpiler

Designed and manufactured in Australia our Mobile Radial Stockpilers are available in 12 and 16 metres. High performance and reliable units backed by our national after sales support and reputation.



LP 12 Metre Mobile Radial Stockpiler

Features:

- Low-maintenance design
- User friendly controls
- Quick set-up
- Easy to transport
- Hydraulic drive
- Feed Hopper Capacity of approx. 1.53m³
- Belt Width: 600mm, 750mm, 900mm
- Power Supply: From auxiliary outlet on associated equipment

OPERATIONAL

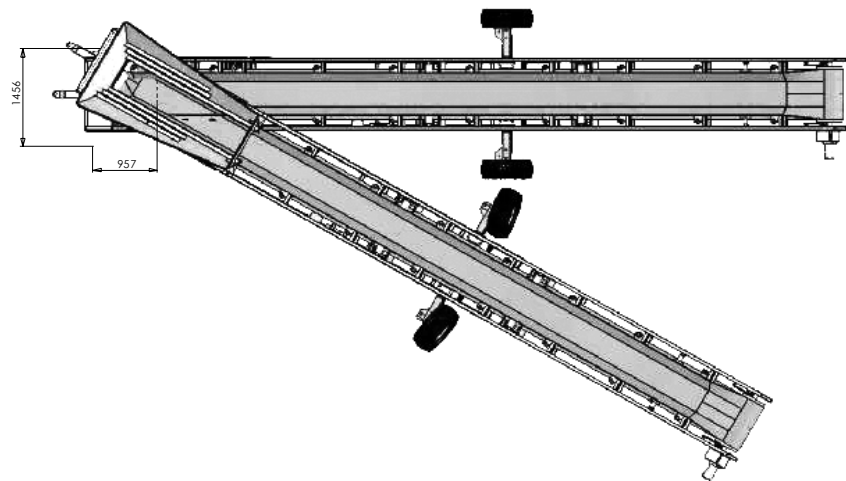

Options:

- Diesel engine
- Hydraulic radial hub
- Large feed bin
- Feed bin liners

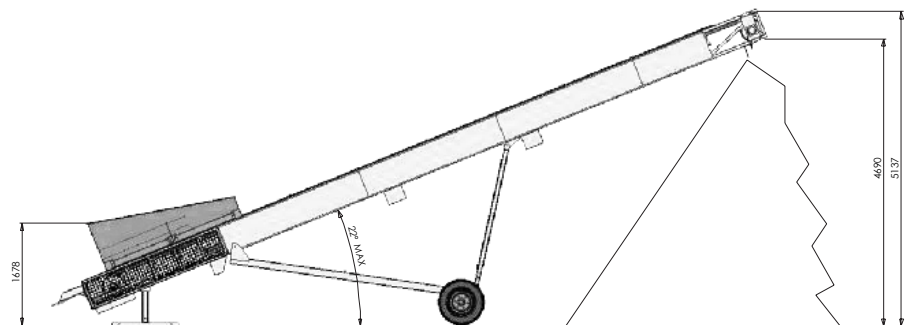

TRANSPORT

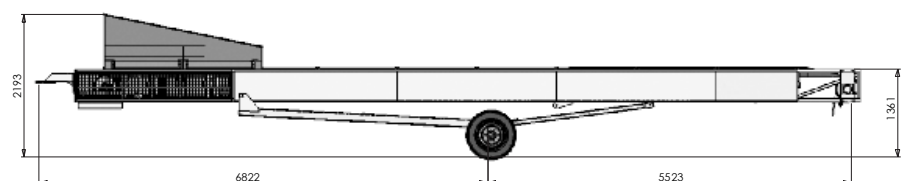

Queensland (Head Office)
Ph: (07) 3293 0888

New South Wales
Ph: (02) 4272 3388

Hunter Region
Ph: (02) 4081 3868

Victoria
Ph: (03) 5335 5088

Western Australia
Ph: (08) 9452 0016

New Zealand
Ph: +64 9 236 2008

www.lincom.com.au
sales@lincom.com.au

LP 16 Metre Mobile Radial Stockpiler

OPERATIONAL

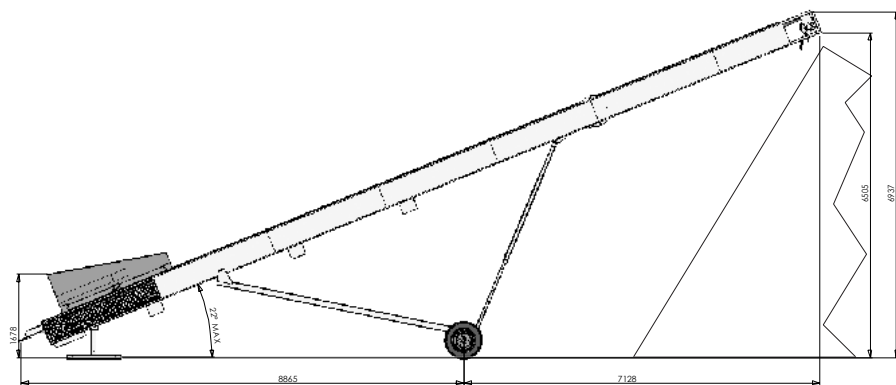
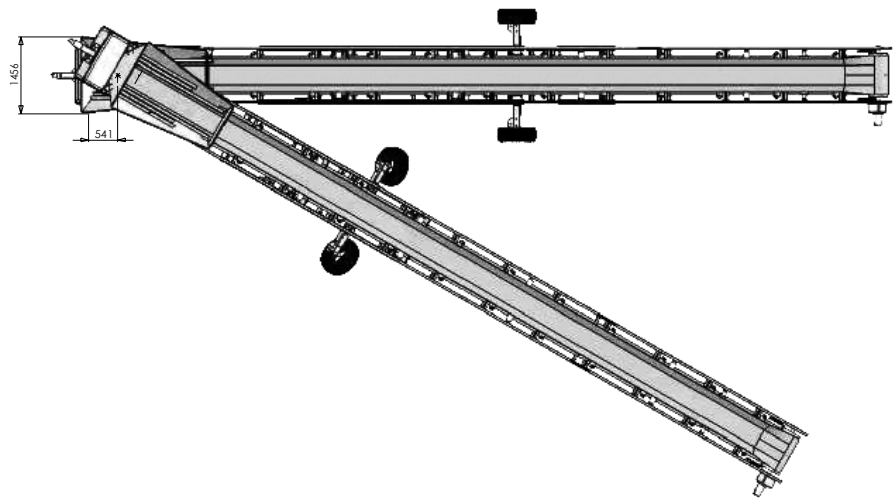

TRANSPORT

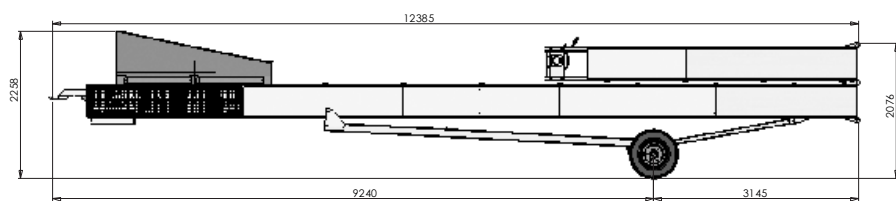

Queensland (Head Office)
Ph: (07) 3293 0888

New South Wales
Ph: (02) 4272 3388

Hunter Region
Ph: (02) 4081 3868

Victoria
Ph: (03) 5335 5088

Western Australia
Ph: (08) 9452 0016

New Zealand
Ph: +64 9 236 2008

www.lincom.com.au
sales@lincom.com.au